

Data Sheet : CCF25W

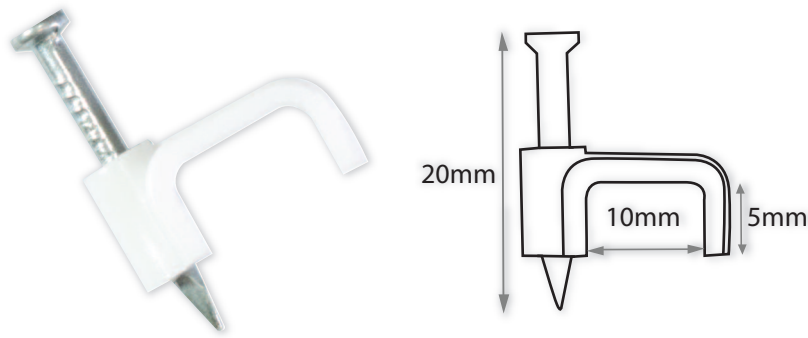

Code	CCF25W
Description	Flat Twin & Earth Cable Clips
To Fit Cable Size	2.5mm Twin & Earth
Range	Selectric Power & Cable Management
Colour	White
Material	ABS clip with a Zinc-plated carbon steel pin
Inner Carton Qty	100
Inner Carton Weight	0.130kg
Barcode	5025117980101
Commodity Code	7317008000
Standards	BS EN 50146
Notes	<ul style="list-style-type: none">• Pack of 100 clips