

# Data Sheet : CCF15W

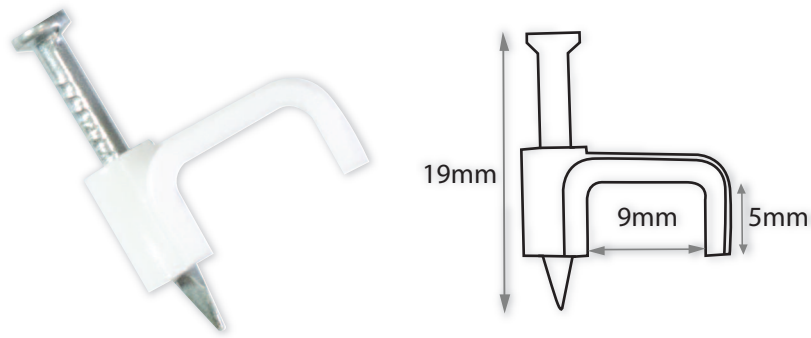

<b>Code</b>	CCF15W
<b>Description</b>	Flat Twin & Earth Cable Clips
<b>To Fit Cable Size</b>	1.5mm Twin & Earth
<b>Range</b>	Selectric Power & Cable Management
<b>Colour</b>	White
<b>Material</b>	ABS clip with a Zinc-plated carbon steel pin
<b>Inner Carton Qty</b>	100
<b>Inner Carton Weight</b>	0.111kg
<b>Barcode</b>	5025117980095
<b>Commodity Code</b>	7317008000
<b>Standards</b>	BS EN 50146
<b>Notes</b>	<ul style="list-style-type: none"><li>• Pack of 100 clips</li></ul>