

Data Sheet:  
**5MPLUS-884**

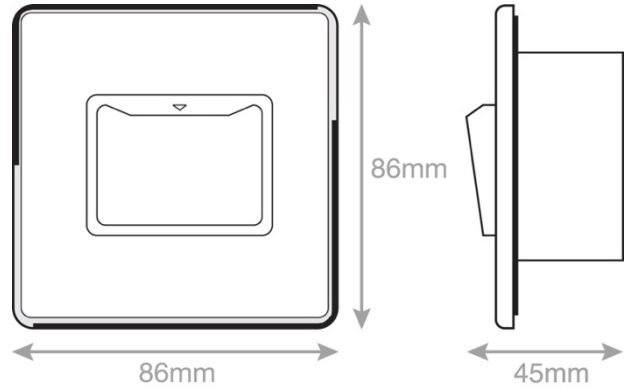

|                               |   |
|-------------------------------|---|
| <b>Code:</b>                  | 5MPLUS-884  |
| <b>Description:</b>           | Hotel Key Cards - 32A 1 Gang Key Card Switch  |
| <b>Range:</b>                 | Selectric 5M-PLUS   |
| <b>Colour:</b>                | Matt Black, Black Insert  |
| <b>Ingress Protection:</b>    | IP20  |
| <b>Material:</b>              | Premium grade steel   |
| <b>Included:</b>              | M3.5 fixing Screws & wiring instructions  |
| <b>Weight:</b>                | 1.97 kg   |
| <b>Inner Carton Quantity:</b> | 10  |
| <b>Inner Carton Weight:</b>   | 19.7 g  |
| <b>Guarantee:</b>             | 2 year guarantee  |
| <b>Barcode:</b>               | 5025117024171   |
| <b>Commodity Code:</b>        | 8536 508090   |
| <b>Standards:</b>             | BS EN 60669   |
| <b>Packaging:</b>             | PP5 Poly Bag with Euro Slot   |
| <b>Notes:</b>                 | <ul style="list-style-type: none"> <li>• To activate power and lighting in hotel rooms via a key card</li> <li>• Backlit for operation in the dark</li> <li>• Suitable for standard cards and credit cards 85.60mm × 53.98 mm</li> <li>• Minimum mounting box 47mm</li> </ul> |



Selectric reserves the right to withdraw, improve, or modify any design without prior notification.  
 Selectric cannot be held responsible for the incorrect application / installation of any product.